

Kunststoff PA

Verschraubungen









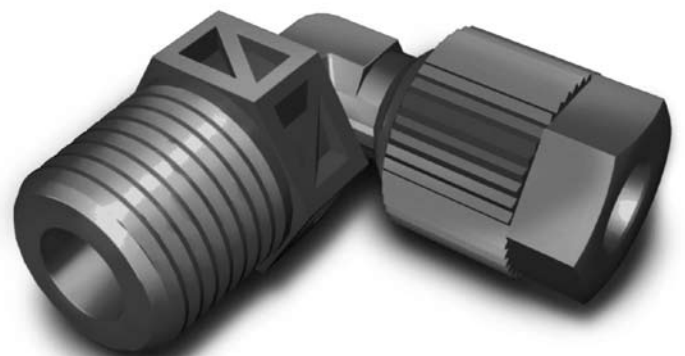







Plastique PA

Raccords

Plastic PA

Unions



Seite/Page/Page		Seite/Page/Page		Seite/Page/Page			
3.3	Klemmring Bague de serrage Compression ferrule		Einstellnippel Union orientable mâle Adjustable male adaptor	3.9	T-Einschraubverschraubung Té mâle Male adaptor tee union		3.15
SO 30001		SO 31600		SO 33721			
3.3	Abschlusszapfen Bouchon d'arrêt Plug		Reduktionsverschraubung Réduction Reduced union	3.11	Schwenverschraubung Coude banjo Single banjo		3.15
SO 30002		SO 31821		SO 32821			
3.4	Rändelmutter Ecroû moleté Knurled nut		Winkelverschraubung Coude Elbow union	3.11	2-fach Winkelschwenverschraubung Coude banjo multiple Double banjo		3.16
SO 30020		SO 32021		SO 32921			
3.4	Gerade Verschraubung Union double Straight union		Winkel-Einschraubverschraubung Coude mâle Male adaptor elbow union	3.12	Schwenverschraubung Coude banjo Single banjo		3.16
SO 31021		SO 32421		SO 37621			
3.5	Gerade Einschraubverschraubung Union mâle Male adaptor union		Einstellwinkel Coude orientable Adjustable elbow union	3.13	Schwenverschraubung Coude banjo Single banjo		3.17
SO 31121		SO 32621		SO 37721			
3.6	Gerade Aufschraubverschraubung Union femelle Female adaptor union		Winkelschottverschraubung Coude pour passage cloison Panel mount elbow union	3.13	Sonderausführungen: Exécution en option: Optional Services:		Spezialreinigung - entfettet Traitement spécial - sans silicone Special treatment - degreased
SO 31221		SO 32721		SO 32721		Vorbeschichtete Gewinde mit Loctite 5061 Filetages pré enduits avec Loctite 5061 Pre-coated threads with Loctite 5061	
3.7	Verbindungsrippel Pièce folle Tube stub		T-Verschraubung Té Tee union	3.14		Vorbeschichtete Gewinde PTFE-Band umwickelt Filetages pré enduits avec ruban en PTFE Pre-coated threads with PTFE-tape	
SO 31300		SO 33021		SO 33021			
3.8	Gerade Schottverschraubung Union double pour passage de cloison Panel mount union		Einstell-T Té orientable Adjustable tee union	3.14			
SO 31521		SO 33621					

Kunststoff PA

Plastique PA

Plastic PA

Eigenschaften, Besonderheiten

- einfache, schnelle Montage
- preisgünstige Verschraubungsreihe
- Kombinationsmöglichkeit mit Messing-, Stahl- und Edelstahl-Verschraubungen
- grosse Sortimentsvielfalt

Funktionsprinzip

siehe Anhang

Anwendung

Hervorragend für Pneumatikanwendungen geeignet. Nicht direkter Sonnenbestrahlung aussetzen.

Werkstoff

Formteile und Nippel aus hitzestabilisiertem Polyamid 6.6, grau.

Nenndruck PN

10 bar bei 23 °C (3fache Sicherheit)

Temperaturbereich

-40 °C bis +80 °C.

Anzuschliessende Röhre

Toleranzhaltige Röhre und Schläuche mit sauberer Oberfläche und gleichmässiger Wandung. Siehe auch Kapitel Röhre und Schläuche.

Généralités

- montage facile et rapide
- prix avantageux
- combinaison possible avec des raccords en matière laiton, acier et acier inoxydable
- gamme complète

Principe de fonctionnement

voir annexe

Application

Les systèmes pneumatiques comme domaine d'application principal. Ne pas exposer directement aux rayons du soleil.

Matériau

Le raccord est réalisé en polyamide 6.6 gris stabilisé à la chaleur.

Pression nominale PN

10 bar à 23 °C (facteur de sécurité 3)

Plage de température admissible

-40 °C à +80 °C.

Tubes à utiliser

Tubes et tuyaux flexibles respectant les tolérances avec surface propre et d'épaisseur de paroi régulière. Voir aussi chapitre tubes et tuyaux.

Characteristics, specialities

- easy and fast to install
- advantageous price
- combinations possible with unions of brass, steel and stainless steel
- extensive range

Operating principle

see appendix

Application

The main field of application is pneumatic tubing. Should not be subjected to direct sunlight.

Material

Moulded body, union nut and ferrule are made of heat-stabilized grey polyamide 6.6.

Nominal pressure PN

10 bar at 23 °C (safety factor 3)

Temperature range

-40 °C to +80 °C.

Tubes to use

True to tolerance tubes and hoses with clean surface and uniform wall thickness. See also chapter tubes and hoses.

Druckauswertungsgrad in % des PN

Coefficient de pression de service admissible en % de PN

Pressure coefficient % of PN

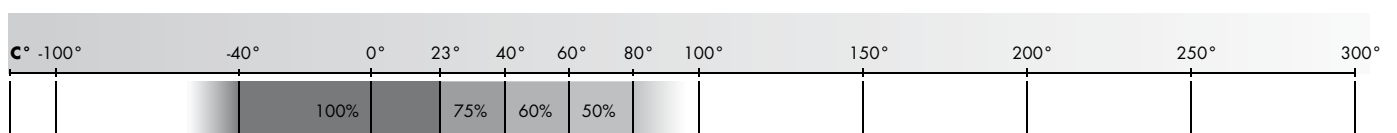

Klemmring

Bague de serrage

Compression ferrule

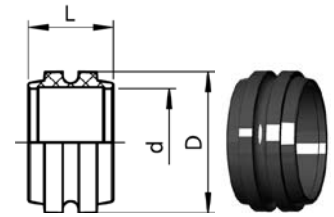

SO 30001

Type -d	Mat.-Nr.	bar	L	D	kg/100
SO 30001-6	166.0010.060	10	6.4	8.6	0.019
SO 30001-8	166.0010.080	10	6.4	10.7	0.025
SO 30001-10	166.0010.100	10	6.9	12.7	0.032
SO 30001-12	166.0010.120	10	7.5	14.8	0.043

Abschlusszapfen

Bouchon d'arrêt

Plug

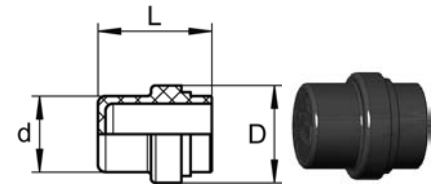

SO 30002

Type -d	Mat.-Nr.	bar	L	D	kg/100
SO 30002-6	166.0020.060	10	12.0	8.8	0.036
SO 30002-8	166.0020.080	10	12.5	10.8	0.051
SO 30002-10	166.0020.100	10	15.0	12.8	0.078
SO 30002-12	166.0020.120	10	17.0	14.8	0.105

Anwendungsbeispiele:

Exemples d'utilisation:

Sample combinations:

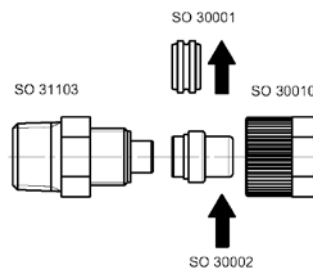

Der Abschlusszapfen SO 30002 lässt sich in jede Verschraubung anstelle eines Klemmringes der gleichen Grösse d einsetzen.

Le bouchon d'arrêt SO 30002 peut remplacer la bague de serrage de même dimension d dans chaque raccord.

The plug SO 30002 can be used in every union instead of a compression ferrule of the same size d.

Rändelmutter Ecrou moleté Knurled nut

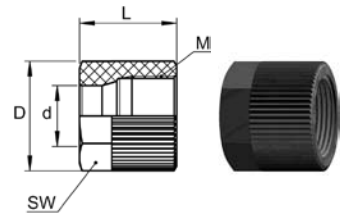

SO 30020

Type -d	Mat.-Nr.	bar	M	SW	L	D	kg/100
SO 30020-6	166.0100.060	10	10 x 1	12	14.5	14.0	0.160
SO 30020-8	166.0100.080	10	12 x 1	14	16.0	16.0	0.210
SO 30020-10	166.0100.100	10	14 x 1	17	17.5	19.5	0.360
SO 30020-12	166.0100.120	10	16 x 1	19	19.5	22.0	0.480

Gerade Verschraubung Union double Straight union

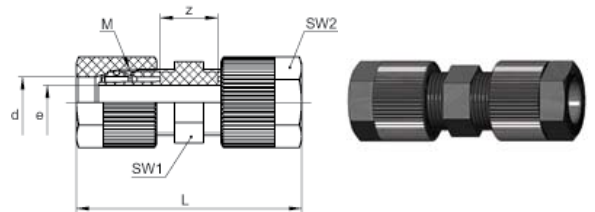

SO 31021

Type -d	Mat.-Nr.	bar	M	SW1	L	z	e	kg/100
SO 31021-6	168.1000.060	10	10 x 1	10	39.0	16.0	2.8	0.513
SO 31021-8	168.1000.080	10	12 x 1	12	42.0	17.5	4.8	0.702
SO 31021-10	168.1000.100	10	14 x 1	14	45.5	17.5	6.6	1.096
▼ SO 31021-10/7	168.1000.102	10	14 x 1	14	45.5	17.5	5.6	1.111
SO 31021-12	168.1000.120	10	16 x 1	17	49.0	16.0	8.0	1.492
▼ SO 31021-12/9	168.1000.122	10	16 x 1	17	49.0	16.0	7.0	1.506

Reduktionen siehe SO 31821

Réductions voir SO 31821

Reductions please see SO 31821

d= Rohraussen-ø
 L= Mass in montiertem Zustand
 e= kleinste Bohrung
 ▼=für Rohre mit Wandung 1,5 mm

d=ø extérieur du tube
 L=après montage
 e=ø-min. de passage
 ▼=pour tubes avec paroi de 1,5 mm d'épaisseur

d=tube outside diameter
 L=installed length
 e=minimum bore
 ▼=for tubes with wall thickness of 1,5 mm

Gerade Einschraubverschraubung

Union mâle

Male adaptor union

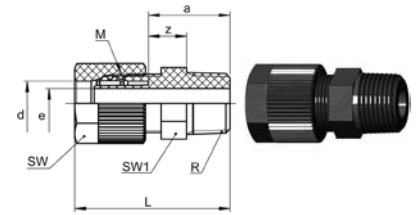

SO 31121

Type -d-R	Mat.-Nr.	bar	M	SW	SW1	L	a	z	e	kg/100
R= Rohrgewinde (kegelig)	R= Filetage-gaz BSP (conique)	R=BSP thread (tapered)								
SO 31121-6-1/8	168.1101.100	10	10 x 1	12	12	30.0	19.0	11.0	2.8	0.143
SO 31121-6-1/4	168.1101.110	10	10 x 1	12	14	35.5	24.5	12.5	2.8	0.302
SO 31121-6-3/8	168.1101.120	10	10 x 1	12	17	36.0	25.0	13.0	2.8	0.460
SO 31121-8-1/8	168.1101.160	10	12 x 1	14	12	31.2	19.0	11.0	4.8	0.175
SO 31121-8-1/4	168.1101.170	10	12 x 1	14	14	36.5	24.5	12.5	4.8	0.328
SO 31121-8-3/8	168.1101.180	10	12 x 1	14	17	37.5	25.0	13.0	4.8	0.485
SO 31121-10-1/4	168.1101.270	10	14 x 1	17	14	38.0	24.0	12.0	6.6	0.352
SO 31121-10-3/8	168.1101.280	10	14 x 1	17	17	38.5	24.5	12.5	6.6	0.508
▼ SO 31121-10/7-1/4	168.1101.320	10	14 x 1	17	14	38.0	24.0	12.0	5.6	0.360
▼ SO 31121-10/7-3/8	168.1101.330	10	14 x 1	17	17	38.5	24.5	12.5	5.6	0.516
SO 31121-12-1/4	168.1101.380	10	16 x 1	19	14	39.5	23.0	11.0	6.6	0.385
SO 31121-12-3/8	168.1101.390	10	16 x 1	19	17	40.0	23.5	11.5	8.0	0.538
SO 31121-12-1/2	168.1101.400	10	16 x 1	19	22	45.0	28.5	12.5	8.0	0.876
▼ SO 31121-12/9-1/4	168.1101.410	10	16 x 1	19	14	39.5	23.0	11.0	6.6	0.394
▼ SO 31121-12/9-3/8	168.1101.412	10	16 x 1	19	17	40.0	23.5	11.5	7.0	0.551
▼ SO 31121-12/9-1/2	168.1101.414	10	16 x 1	19	22	45.0	28.5	12.5	7.0	0.879

Gerade Einschraubverschraubung NPT

Union mâle NPT

Male adaptor union NPT

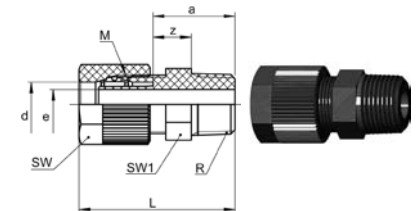

SO 31121 NPT

Type -NPT	Mat.-Nr.	bar	M	SW	SW1	L	a	z	e	kg/100
R= NPT Gewinde	R= Filetage NPT	R= NPT thread (tapered)								
SO 31121-6-1/8 NPT	168.1102.100	10	10 x 1	12	11	32.0	21.0	11.0	2.8	0.165
SO 31121-6-1/4 NPT	168.1102.110	10	10 x 1	12	14	37.5	26.5	12.5	2.8	0.293
SO 31121-8-1/8 NPT	168.1102.160	10	12 x 1	14	11	33.0	21.0	11.0	4.8	0.193
SO 31121-8-1/4 NPT	168.1102.170	10	12 x 1	14	14	38.5	26.5	12.5	4.8	0.321
SO 31121-10-1/4 NPT	168.1102.270	10	14 x 1	17	14	40.0	26.0	12.0	6.6	0.347
SO 31121-10-3/8 NPT	168.1102.280	10	14 x 1	17	17	40.5	26.5	12.5	6.6	0.500
▼ SO 31121-10/7-1/4 NPT	168.1102.320	10	14 x 1	17	14	40.0	26.0	12.0	5.6	0.353
▼ SO 31121-10/7-3/8 NPT	168.1102.330	10	14 x 1	17	17	40.5	26.5	12.5	5.6	0.508

Zum Abdichten der Einschraubgewinde empfehlen wir unseren Dichtstift «Plasto-Joint» AC 833.
Reduktionen siehe SO 31821

Pour assurer l'étanchéité des filetages mâles, nous recommandons notre bâton «Plasto-Joint» AC 833.
Réductions voir SO 31821

For sealing the male threads we recommend our sealing stick «Plasto-Joint» AC 833.
Reductions please see SO 31821

d=Rohrassens-ø
e= kleinste Bohrung
L= Mass in montiertem Zustand
▼=für Rohre mit Wandung 1,5 mm

d=ø extérieur du tube
e= ø-min. de passage
L=après montage
▼=pour tubes avec paroi de 1,5 mm d'épaisseur

d=tube outside diameter
e=minimum bore
L=installed length
▼=for tubes with wall thickness of 1,5 mm

Gerade Einschraubverschraubung

Dichtung mit O-Ring (NBR)

Union mâle

avec joint torique (NBR)

Male adaptor union

with O-Ring seal (NBR)

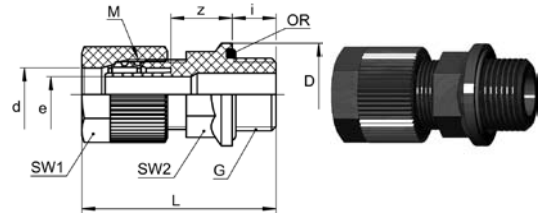

SO 31124 OR

Type -d-G	Mat.-Nr.	bar	M	SW1	SW2	L	D1	i	z	e	kg/100
G= Rohrgewinde (zylindrisch)	G= Filetage-gaz BSP (cylindrique)		G=BSP thread (straight)								
SO 31124-6-1/8 OR	168.1171.100	10	10x1	12	10	34.5	16.0	8.0	15.5	2.8	0.378
SO 31124-6-1/4 OR	168.1171.110	10	10x1	12	13	36.5	19.5	10.0	15.5	2.8	0.482
SO 31124-6-3/8 OR	168.1171.120	10	10x1	12	17	37.5	23.5	10.0	16.5	2.8	0.695
SO 31124-8-1/8 OR	168.1171.160	10	12x1	14	10	35.5	16.0	8.0	15.5	4.8	0.462
SO 31124-8-1/4 OR	168.1171.170	10	12x1	14	13	37.5	19.5	10.0	15.5	4.8	0.557
SO 31124-8-3/8 OR	168.1171.180	10	12x1	14	17	38.5	23.5	10.0	16.5	4.8	0.758
SO 31124-10-1/4 OR	168.1171.270	10	14x1	17	13	39.0	19.5	10.0	15.0	6.6	0.737
SO 31124-10-3/8 OR	168.1171.280	10	14x1	17	17	40.0	23.5	10.0	16.0	6.6	0.924
SO 31124-10-1/2 OR	168.1171.285	10	14x1	17	19	45.0	30.0	12.0	19.0	6.6	1.210
SO 31124-12-1/4 OR	168.1171.380	10	16x1	19	13	41.5	19.5	10.0	14.0	8.0	0.897
SO 31124-12-3/8 OR	168.1171.390	10	16x1	19	17	41.5	23.5	10.0	15.0	8.0	1.092
SO 31124-12-1/2 OR	168.1171.400	10	16x1	19	19	46.5	30.0	12.0	18.0	8.0	1.376

Gerade Aufschraubverschraubung

Union femelle

Female adaptor union

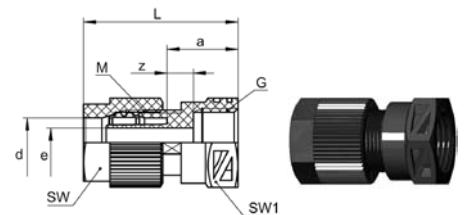

SO 31221

Typ -d-G	Mat.-Nr.	bar	M	SW	SW1	L	a	z	e	kg/100	
G= Rohrgewinde (zylindrisch)	G= Filetage-gaz BSP (cylindrique)		G=BSP thread (straight)								
SO 31221-6-1/8	168.1201.100	10	10x1	12	14	29.0	18.0	9.0	2.8	0.309	
SO 31221-6-1/4	168.1201.110	10	10x1	12	17	30.0	19.0	9.0	2.8	0.379	
SO 31221-6-3/8	168.1201.120	10	10x1	12	22	31.0	20.0	9.0	2.8	0.526	
SO 31221-6-1/2	168.1201.125	10	10x1	12	27	34.5	23.5	9.5	2.8	0.864	
SO 31221-8-1/8	168.1201.160	10	12x1	14	14	30.0	18.0	9.0	4.8	0.376	
SO 31221-8-1/4	168.1201.170	10	12x1	14	17	31.0	19.0	9.0	4.8	0.453	
SO 31221-8-3/8	168.1201.180	10	12x1	14	22	33.0	20.0	9.0	4.8	0.587	
SO 31221-8-1/2	168.1201.185	10	12x1	14	27	35.5	23.5	9.5	4.8	0.938	
SO 31221-10-1/4	168.1201.270	10	14x1	17	17	33.5	18.5	8.5	6.6	0.602	
SO 31221-10-3/8	168.1201.280	10	14x1	17	22	34.5	19.5	8.5	6.6	0.742	
SO 31221-10-1/2	168.1201.285	10	14x1	17	27	37.0	23.0	9.0	6.6	1.074	
▼ SO 31221-10/7-1/4	168.1201.320	10	14x1	17	17	33.0	18.5	8.5	5.0	0.615	
▼ SO 31221-10/7-3/8	168.1201.330	10	14x1	17	22	34.0	19.5	8.5	5.0	0.755	
SO 31221-12-3/8	168.1201.390	10	16x1	19	22	35.0	18.5	7.5	7.0	0.883	
SO 31221-12-1/2	168.1201.400	10	16x1	19	27	37.5	22.0	8.0	8.0	1.234	
▼ SO 31221-12/9-3/8	168.1201.412	10	16x1	19	22	35.0	18.5	7.5	7.0	0.908	
▼ SO 31221-12/9-1/2	168.1201.414	10	16x1	19	27	37.5	22.0	8.0	8.0	1.253	

d=Rohrassen-ø
 e= kleinste Bohrung
 L= Mass in montiertem Zustand
 ▼=für Rohre mit Wandung 1,5 mm

d=ø extérieur du tube
 e= ø-min. de passage
 L=après montage
 ▼=pour tubes avec paroi de 1,5 mm d'épaisseur

d=tube outside diameter
 e=minimum bore
 L=installed length
 ▼=for tubes with wall thickness of 1,5 mm

Verbindungsrippel

Pièce folle

Tube stub

SO 31300

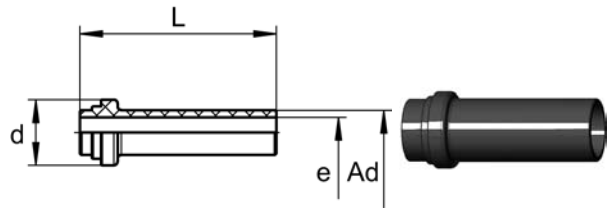

Type -d -Ad	Mat.-Nr.	bar	L	D	e	kg/100
SO 31300-6-A6	166.1300.060	10	27.0	8.7	4.0	0.060
SO 31300-8-A8	166.1300.080	10	28.0	10.8	6.0	0.085
SO 31300-10-A10	166.1300.100	10	33.0	12.8	8.0	0.127
SO 31300-12-A12	166.1300.120	10	37.0	14.7	10.0	0.171
▼ SO 31300-12/9-A12/9	166.1300.122	10	37.0	14.7	9.0	0.233

Verbindungsrippel reduziert

Pièce folle réduite

Reducing port connector

SO 31300 RED

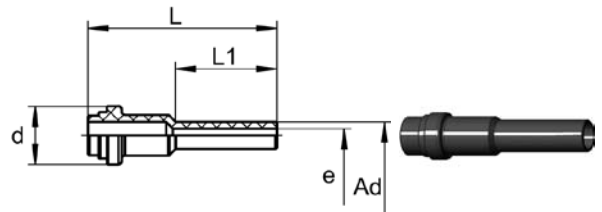

Type -d -Ad	Mat.-Nr.	bar	L	L1	D	e	kg/100
SO 31300-8-A6 RED	166.1304.140	10	30.0	15.0	10.6	4.0	0.080
SO 31300-10-A6 RED	166.1304.175	10	35.0	15.0	12.6	4.0	0.113
SO 31300-10-A8 RED	166.1304.190	10	35.0	15.0	12.6	6.0	0.124
SO 31300-12-A8 RED	166.1304.225	10	39.0	19.0	14.6	6.0	0.150
SO 31300-12-A10 RED	166.1304.240	10	39.0	19.0	14.6	8.0	0.166

Anwendungsbeispiele:

Exemples d'utilisation:

Sample combinations:

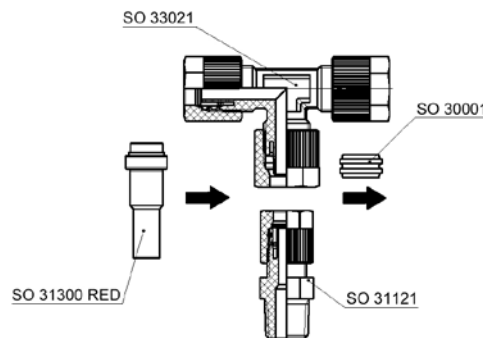

d=Rohraussen-ø
 Ad=Aussen-ø der Andrehung
 e= kleinste Bohrung
 L= Mass in montiertem Zustand
 ▼=für Rohre mit Wandung 1,5 mm

d=ø extérieur du tube
 Ad=ø extérieur de la portée cylindrique
 e= ø-min. de passage
 L=après montage
 ▼=pour tubes avec paroi de 1,5 mm d'épaisseur

d=tube outside diameter
 Ad= outside diameter of cyl. Stub
 e=minimum bore
 L=installed length
 ▼=for tubes with wall thickness of 1,5 mm

Gerade Schottverschraubung
Union double pour passage de cloison
Panel mount union

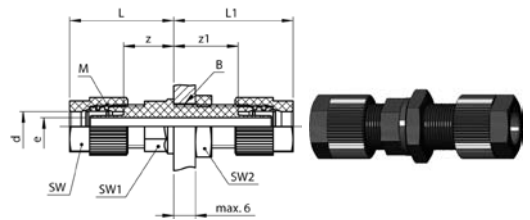

SO 31521

Type -d	Mat.-Nr.	bar	M	SW	SW1	SW2	L	L1	B	z1	z	e	kg/100
SO 31521-6	168.1500.060	10	10 x 1	12	14	14	24.0	28.0	10.5	17.0	13.0	2.8	0.678
SO 31521-8	168.1500.080	10	12 x 1	14	12	17	26.5	30.0	12.5	18.0	14.0	4.8	0.938
SO 31521-10	168.1500.100	10	14 x 1	17	14	19	28.5	31.5	14.5	17.5	14.0	6.6	1.387
▼ SO 31521-10/7	168.1500.102	10	14 x 1	17	14	19	28.5	32.0	14.5	17.5	14.0	5.6	1.417
SO 31521-12	168.1500.120	10	16 x 1	19	17	19	31.0	37.5	16.5	20.0	13.5	8.0	1.917
▼ SO 31521-12/9	168.1500.122	10	16 x 1	19	17	19	31.0	37.5	16.5	20.0	13.5	7.0	1.957

Sechskantmutter SO 40006
 Reduktionen siehe SO 31821

Ecrou à six pans SO 40006
 Réductions voir SO 31821

Hexagon nut SO 40006
 Reductions please see SO 31821

d=Rohrassens-ø
 e= kleinste Bohrung
 L= Mass in montiertem Zustand
 ▼=für Rohre mit Wandung 1,5 mm

d=ø extérieur du tube
 e= ø-min. de passage
 L=après montage
 ▼=pour tubes avec paroi de 1,5 mm d'épaisseur

d=tube outside diameter
 e=minimum bore
 L=installed length
 ▼=for tubes with wall thickness of 1,5 mm

Einstellnippel

Union orientable mâle

Adjustable male adaptor

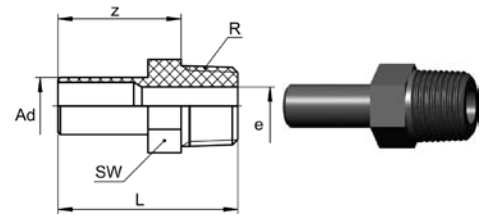

SO 31600

Type -Ad-R	Mat.-Nr.	bar	SW	L	f	z	e	kg/100
R= Rohrgewinde (kegelig)	R= Filetage-gaz BSP (conique)	R=BSP thread (tapered)						
SO 31600-A6-1/8	166.1601.100	10	10	26.0	13.0	13.0	4.0	0.110
SO 31600-A6-1/4	166.1601.110	10	14	31.5	13.0	18.0	4.0	0.268
SO 31600-A6-3/8	166.1601.120	10	17	32.0	13.0	19.5	4.0	0.410
SO 31600-A8-1/8	166.1601.160	10	10	27.0	14.0	20.0	5.0	0.124
SO 31600-A8-1/4	166.1601.170	10	14	32.5	14.0	21.0	6.0	0.282
SO 31600-A8-3/8	166.1601.180	10	17	33.0	14.0	20.5	6.0	0.429
SO 31600-A10-1/4	166.1601.270	10	14	33.5	15.0	21.0	6.7	0.285
SO 31600-A10-3/8	166.1601.280	10	17	34.0	15.0	21.5	8.0	0.442
SO 31600-A10-1/2	166.1601.285	10	22	39.0	15.0	22.0	8.0	0.760
SO 31600-A12-1/4	166.1601.380	10	14	37.5	19.0	23.0	6.7	0.315
SO 31600-A12-3/8	166.1601.390	10	17	38.0	19.0	25.5	8.0	0.464
SO 31600-A12-1/2	166.1601.400	10	22	43.0	19.0	27.0	10.0	0.798

Anwendungsbeispiele:

Exemples d'utilisation:

Sample combinations:

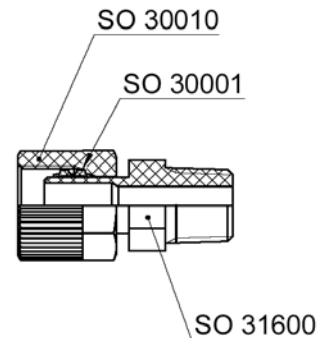
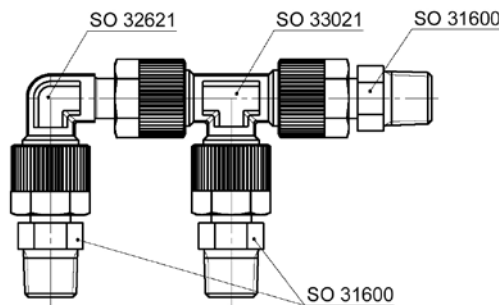
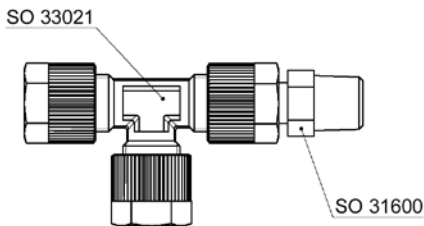

d=Rohrussen-ø
e= kleinste Bohrung
L= Mass in montiertem Zustand

d=ø extérieur du tube
e= ø-min. de passage
L=après montage

d=tube outside diameter
e=minimum bore
L=installed length

Einstellnippel

Dichtung mit O-Ring (NBR)

Union orientable mâle

avec joint torique (NBR)

Adjustable male adaptor

with O-Ring seal (NBR)

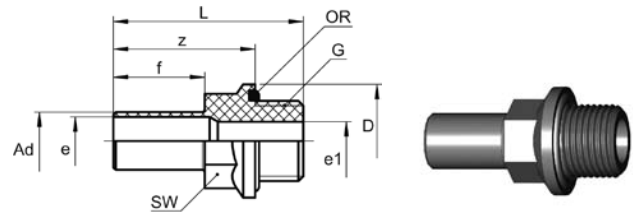

SO 31624 OR

Type -Ad -G	Mat.-Nr.	bar	SW	L	D	e1	f	z	e	kg/100
G= Rohrgewinde (zylindrisch)	G= Filetage-gaz BSP (cylindrique)	G=BSP thread (straight)								
SO 31624-A6-1/8 OR	166.1681.100	10	10	30.5	16.0	5.1	13.0	22.5	4.0	0.175
SO 31624-A6-1/4 OR	166.1681.110	10	13	32.5	19.5	7.8	13.0	22.5	4.0	0.274
SO 31624-A6-3/8 OR	166.1681.120	10	17	33.5	23.5	9.8	13.0	23.5	4.0	0.470
SO 31624-A8-1/8 OR	166.1681.160	10	10	31.5	16.0	5.1	14.0	23.5	6.0	0.183
SO 31624-A8-1/4 OR	166.1681.170	10	13	33.5	19.5	7.8	14.0	23.5	6.0	0.287
SO 31624-A8-3/8 OR	166.1681.180	10	17	34.5	23.5	9.8	14.0	24.5	6.0	0.482
SO 31624-A10-1/4 OR	166.1681.270	10	13	34.5	19.5	8.0	15.0	24.5	8.0	0.298
SO 31624-A10-3/8 OR	166.1681.280	10	17	35.5	23.5	9.8	15.0	25.5	8.0	0.482
SO 31624-A10-1/2 OR	166.1681.285	10	19	40.5	30.0	14.0	15.0	28.5	8.0	0.768
SO 31624-A12-1/4 OR	166.1681.380	10	13	38.5	19.5	7.8	19.0	28.5	10.0	0.326
SO 31624-A12-3/8 OR	166.1681.390	10	17	39.5	23.5	10.0	19.0	29.5	10.0	0.511
SO 31624-A12-1/2 OR	166.1681.400	10	19	44.5	30.0	14.0	19.0	32.5	10.0	0.794

3

Anwendungsbeispiele:

Exemples d'utilisation:

Sample combinations:

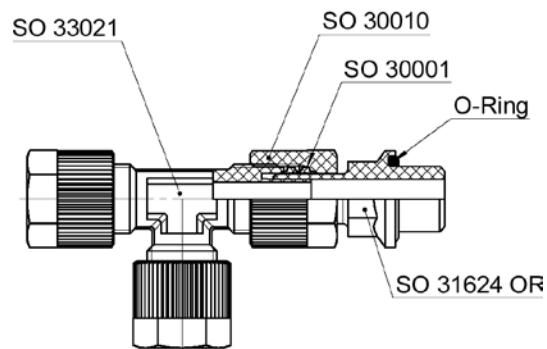
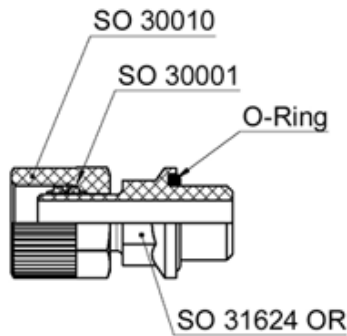

Ad=Aussen-ø der Andrehung
e= kleinste Bohrung
L= Mass in montiertem Zustand

Ad=ø extérieur de la portée cylindrique
e= ø-min. de passage
L=après montage

Ad= outside diameter of cyl. Stub
e=minimum bore
L=installed length

Reduktionsverschraubung

Réduction

Reduced union

SO 31821

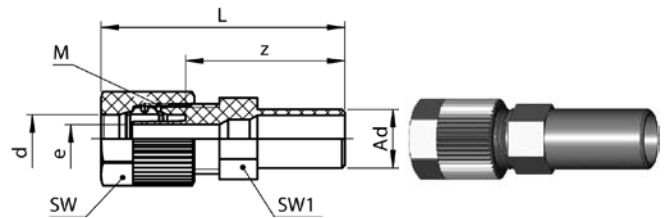

Type -Ad -d	Mat.-Nr.	bar	M	SW	SW1	L	f	z	e	kg/100
SO 31821-A8-6	168.1800.140	10	10 x 1	12	10	35.5	14.0	25.8	2.8	0.301
SO 31821-A10-6	168.1800.175	10	10 x 1	12	10	39.0	15.0	27.5	2.8	0.308
SO 31821-A10-8	168.1800.190	10	12 x 1	14	12	39.5	15.0	27.5	4.8	0.415
SO 31821-A12-6	168.1800.215	10	10 x 1	12	10	42.0	19.0	32.0	2.8	0.348
SO 31821-A12-8	168.1800.225	10	12 x 1	14	12	43.5	19.0	32.0	4.8	0.436
SO 31821-A12-10	168.1800.240	10	14 x 1	17	14	45.0	19.0	31.5	6.6	0.500
▼ SO 31821-A12-10/7	168.1800.242	10	14 x 1	17	14	45.0	19.0	31.5	5.6	0.667

Anwendungsbeispiele:

Exemples d'utilisation:

Sample combinations:

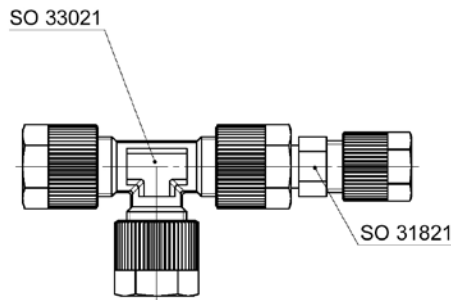

Mit dieser Reduktion können Verschraubungen reduziert werden.

Cette réduction permet de réduire les raccords.

Unions can be reduced with this reduction.

Winkelverschraubung

Coude

Elbow union

SO 32021

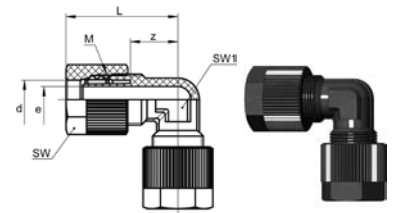

Type -d	Mat.-Nr.	bar	M	SW	SW1	L	z	e	kg/100
SO 32021-6	168.2000.060	10	10 x 1	12	8	25.0	14.0	2.8	0.546
SO 32021-8	168.2000.080	10	12 x 1	14	10	26.5	14.5	4.8	0.743
SO 32021-10	168.2000.100	10	14 x 1	17	12	30.0	16.0	6.6	1.178
▼ SO 32021-10/7	168.2000.102	10	14 x 1	17	12	30.0	16.0	5.6	1.209
SO 32021-12	168.2000.120	10	16 x 1	19	13	32.5	16.0	8.0	1.545
▼ SO 32021-12/9	168.2000.122	10	16 x 1	19	13	32.5	16.0	7.0	1.580

Reduktionen siehe SO 31821

Réductions voir SO 31821

Reductions please see SO 31821

d=Rohrassen-ø
Ad=Aussen-ø der Andrehung
e= kleinste Bohrung
L= Mass in montiertem Zustand
▼=für Rohre mit Wandung 1,5 mm

d=ø extérieur du tube
Ad=ø extérieur de la portée cylindrique
e= ø-min. de passage
L=après montage
▼=pour tubes avec paroi de 1,5 mm d'épaisseur

d=tube outside diameter
Ad= outside diameter of cyl. Stub
e=minimum bore
L=installed length
▼=for tubes with wall thickness of 1,5 mm

Winkel-Einschraubverschraubung

Coude mâle

Male adaptor elbow union

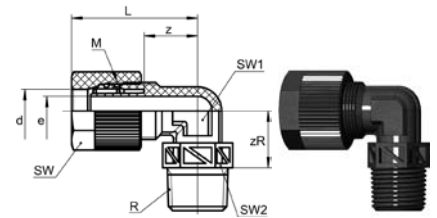

SO 32421

Type -d -R	Mat.-Nr.	bar	M	SW	SW1	SW2	L	zR	z	e	kg/100
R= Rohrgewinde (kegelig)	R= Filetage-gaz BSP (conique)	R=BSP thread (tapered)									
SO 32421-6-1/8	168.2401.100	10	10x1	12	8	10	25.0	11.0	14.0	2.8	0.387
SO 32421-6-1/4	168.2401.110	10	10x1	12	8	14	25.0	12.5	14.0	2.8	0.528
SO 32421-8-1/8	168.2401.160	10	12x1	14	10	10	26.5	12.0	14.5	4.8	0.499
SO 32421-8-1/4	168.2401.170	10	12x1	14	10	14	26.5	13.5	14.5	4.8	0.640
SO 32421-10-1/4	168.2401.270	10	14x1	17	12	14	30.0	14.5	16.0	6.6	0.877
SO 32421-10-3/8	168.2401.280	10	14x1	17	12	17	29.5	15.0	15.5	6.6	1.016
▼ SO 32421-10/7-1/4	168.2401.320	10	14x1	17	12	14	30.0	14.5	16.0	5.6	0.892
▼ SO 32421-10/7-3/8	168.2401.330	10	14x1	17	12	17	30.0	15.0	16.0	5.6	1.031
SO 32421-12-1/4	168.2401.380	10	16x1	19	13	14	32.5	15.5	16.0	8.0	1.080
SO 32421-12-3/8	168.2401.390	10	16x1	19	13	17	32.5	16.0	16.0	8.0	1.207
SO 32421-12-1/2	168.2401.400	10	16x1	19	13	22	32.5	19.5	16.0	8.0	1.574
▼ SO 32421-12/9-1/4	168.2401.410	10	16x1	19	13	14	32.5	15.5	16.0	7.0	1.098
▼ SO 32421-12/9-3/8	168.2401.412	10	16x1	19	13	17	32.5	16.0	16.0	7.0	1.224
▼ SO 32421-12/9-1/2	168.2401.414	10	16x1	19	13	22	32.5	19.5	16.0	7.0	1.607

Winkel-Einschraubverschraubung NPT

Coude mâle NPT

Male adaptor elbow union NPT

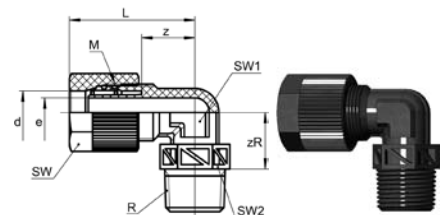

SO 32421 NPT

Type -NPT	Mat.-Nr.	bar	M	SW	SW1	SW2	L	zR	z	e	kg/100
R= NPT Gewinde	R= Filetage NPT	R= NPT thread (tapered)									
SO 32421-6-1/8 NPT	168.2402.100	10	10x1	12	8	11	25.0	11.0	14.0	2.8	0.419
SO 32421-6-1/4 NPT	168.2402.110	10	10x1	12	8	14	25.0	12.5	14.0	2.8	0.559
SO 32421-8-1/8 NPT	168.2402.160	10	12x1	14	10	11	26.5	12.0	14.5	4.8	0.532
SO 32421-8-1/4 NPT	168.2402.170	10	12x1	14	10	14	26.5	13.5	14.5	4.8	0.672
SO 32421-10-1/4 NPT	168.2402.270	10	14x1	17	12	14	30.0	14.5	16.0	6.6	0.905
SO 32421-10-3/8 NPT	168.2402.280	10	14x1	17	12	17	30.0	15.0	16.0	6.6	1.057
▼ SO 32421-10/7-1/4 NPT	168.2402.320	10	14x1	17	12	14	30.0	14.5	16.0	5.6	0.920
▼ SO 32421-10/7-3/8 NPT	168.2402.330	10	14x1	17	12	17	30.0	15.0	16.0	5.6	1.072

Zum Abdichten der Einschraubgewinde empfehlen wir unseren Dichtstift «Plasto-Joint» AC 833.
Reduktionen siehe SO 31821

Pour assurer l'étanchéité des filetages mâles, nous recommandons notre bâton «Plasto-Joint» AC 833.
Réductions voir SO 31821

For sealing the male threads we recommend our sealing stick «Plasto-Joint» AC 833.
Reductions please see SO 31821

d=Rohrassens-ø
e= kleinste Bohrung
L= Mass in montiertem Zustand
▼=für Rohre mit Wandung 1,5 mm

d=ø extérieur du tube
e= ø-min. de passage
L=après montage
▼=pour tubes avec paroi de 1,5 mm d'épaisseur

d=tube outside diameter
L=installed length
e=minimum bore
▼=for tubes with wall thickness of 1,5 mm

Einstellwinkel
Coude orientable
Adjustable elbow union

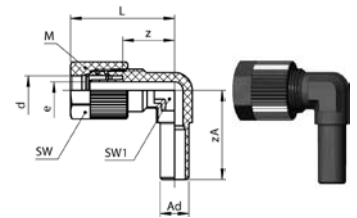

SO 32621

Type -d -Ad	Mat.-Nr.	bar	M	SW	SW1	L	f	zA	z	e	kg/100
SO 32621-6-A6	168.2600.060	10	10 x 1	12	8	25.0	14.0	24.0	14.0	2.8	0.353
SO 32621-8-A8	168.2600.080	10	12 x 1	14	10	26.5	16.0	25.0	14.5	4.8	0.486
SO 32621-10-A10	168.2600.100	10	14 x 1	17	12	30.0	18.0	29.0	16.0	6.6	0.755
SO 32621-12-A12	168.2600.120	10	16 x 1	19	13	32.5	21.0	32.0	16.0	8.0	0.983

Anwendungsbeispiele:

Exemples d'utilisation:

Sample combinations:

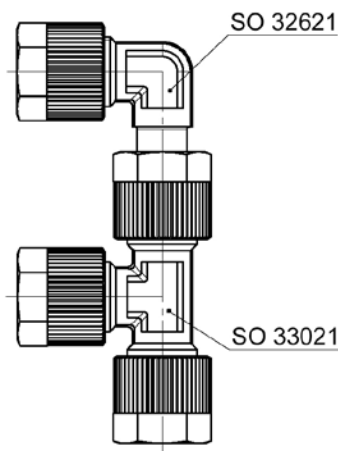

Gegenüber dem Einschraubwinkel lässt sich diese Kombination einfacher einstellen, da Einschrauben und Ausrichten getrennt voneinander vorgenommen werden.
 Reduktionen siehe SO 31821

Contrairement au coude mâle, cette combinaison permet un positionnement plus facile, car l'emboîtement et l'alignement s'ajustent séparément.
 Réductions voir SO 31821

In contrast to the simple male adaptor elbow union, this combination is easier to adjust, since screw-on and aligning are performed separately.
 Reductions please see SO 31821

Winkelschottverschraubung
Coude pour passage cloison
Panel mount elbow union

SO 32721

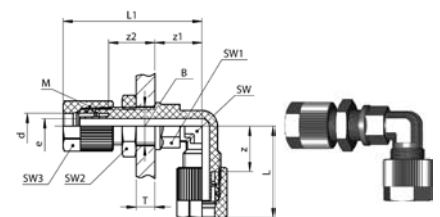

Type -d	Mat.-Nr.	bar	M	SW1	SW2	z	SW3	L	L1	z1	T	e	kg/100
SO 32721-6	168.2700.060	10	10 x 1	10	14	14.0	12	25.0	40.0	13.0	6.0	2.8	1.234
SO 32721-8	168.2700.080	10	12 x 1	12	17	14.5	14	26.5	43.0	15.0	6.0	4.8	1.040
SO 32721-10	168.2700.100	10	14 x 1	14	19	16.0	17	30.0	46.0	16.5	6.0	6.6	1.490
SO 32721-12	168.2700.120	10	16 x 1	17	19	16.0	19	32.5	48.5	17.5	5.0	8.0	2.000

Sechskantmutter SO 40006

Ecrou à six pans SO 40006

Hexagon nut SO 40006

d=Rohrassen- \varnothing
 Ad=Aussen- \varnothing der Andrehung
 e= kleinste Bohrung
 L= Mass in montiertem Zustand

d= \varnothing extérieur du tube
 Ad= \varnothing extérieur de la portée cylindrique
 e= \varnothing -min. de passage
 L=après montage

d=tube outside diameter
 Ad=outside diameter of cyl. Stub
 e=minimum bore
 L=installed length

T-Verschraubung

Té

Tee union

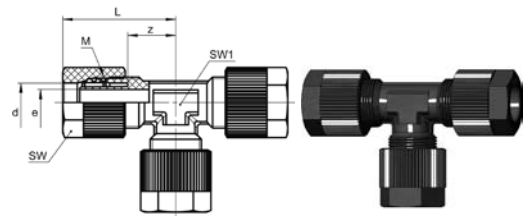

SO 33021

Type -d	Mat.-Nr.	bar	M	SW	SW1	L	z	e	kg/100
SO 33021-6	168.3000.060	10	10 x 1	12	8	25.0	14.0	2.8	0.804
SO 33021-8	168.3000.080	10	12 x 1	14	10	26.5	14.5	4.8	1.089
SO 33021-10	168.3000.100	10	14 x 1	17	12	30.0	16.0	6.6	1.724
▼ SO 33021-10/7	168.3000.102	10	14 x 1	17	12	30.0	16.0	5.6	1.766
SO 33021-12	168.3000.120	10	16 x 1	19	13	32.5	16.0	8.0	2.267
▼ SO 33021-12/9	168.3000.122	10	16 x 1	19	13	32.5	16.0	7.0	2.313

Einstell-T

Té orientable

Adjustable tee union

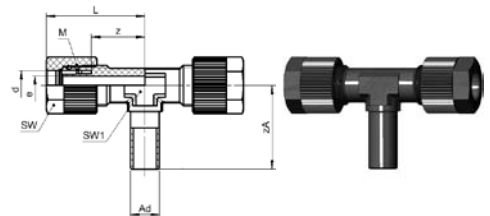

SO 33621

Type -d -Ad -d	Mat.-Nr.	bar	M	SW	SW1	L	f	zA	z	e	kg/100
SO 33621-6-A6-6	168.3600.060	10	10 x 1	12	8	25.0	14.0	24.0	14.0	2.8	0.618
SO 33621-8-A8-8	168.3600.080	10	12 x 1	14	10	26.5	16.0	25.0	14.5	4.8	0.850
SO 33621-10-A10-10	168.3600.100	10	14 x 1	17	12	30.0	20.0	29.0	16.0	6.6	1.304
SO 33621-12-A12-12	168.3600.120	10	16 x 1	19	13	32.5	21.0	30.0	16.0	8.0	1.715

Anwendungsbeispiele:

Exemples d'utilisation:

Sample combinations:

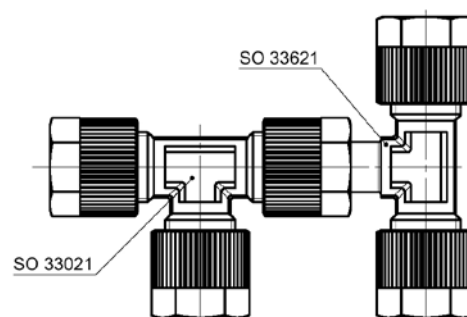
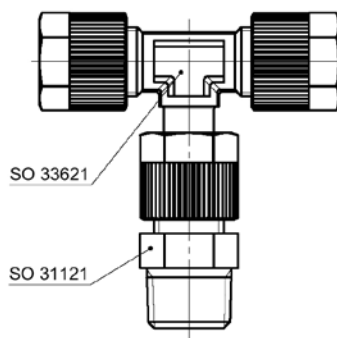

Gegenüber dem Einschraub-T lässt sich diese Kombination einfacher einstellen, da Einschrauben und Ausrichten getrennt voneinander vorgenommen werden. Reduktionen siehe SO 31821

Par opposition à un coude mâle, cette combinaison permet un positionnement plus facile. Le raccordement et l'orientation se font séparément. Réductions voir SO 31821

In contrast to the simple male adaptor elbow union, this combination is easier to adjust, since screw-on and aligning are performed separately. Reductions please see SO 31821

d=Rohrassens-ø
Ad=Aussen-ø der Andrehung
e=kleinste Bohrung
L=Mass in montiertem Zustand
▼=für Rohre mit Wandung 1,5 mm

d=ø extérieur du tube
Ad=ø extérieur de la portée cylindrique
e=ø-min. de passage
L=après montage
▼=pour tubes avec paroi de 1,5 mm d'épaisseur

d=tube outside diameter
Ad=outside diameter of cyl. Stub
e=minimum bore
L=installed length
▼=for tubes with wall thickness of 1,5 mm

T-Einschraubverschraubung

Té mâle

Male adaptor tee union

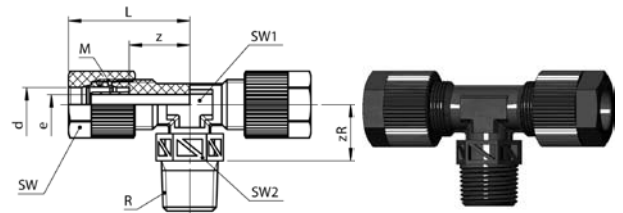
SO 33721

Type -d-R-d	Mat.-Nr.	bar	M	SW	SW1	L	zR	z	e	kg/100
R= Rohrgewinde (kegelig)	R= Filetage-gaz BSP (conique)	R=BSP thread (tapered)								
SO 33721-6-1/8-6	168.3701.100	10	10 x 1	12	10	25.0	11.0	14.0	2.8	0.645
SO 33721-6-1/4-6	168.3701.110	10	10 x 1	12	14	25.0	12.5	14.0	2.8	0.499
SO 33721-8-1/8-8	168.3701.160	10	12 x 1	14	10	26.5	12.0	14.5	4.8	0.814
SO 33721-8-1/4-8	168.3701.170	10	12 x 1	14	10	26.5	13.5	14.5	4.8	0.984
SO 33721-10-1/4-10	168.3701.270	10	14 x 1	17	14	30.0	14.5	16.0	6.6	1.420
SO 33721-10-3/8-10	168.3701.280	10	14 x 1	17	17	30.0	15.0	16.0	6.6	1.561
▼ SO 33721-10/7-1/4-10/7	168.3701.320	10	14 x 1	17	14	30.0	14.5	16.0	5.6	1.448
▼ SO 33721-10/7-3/8-10/7	168.3701.330	10	14 x 1	17	17	30.0	15.0	16.0	5.6	1.387

Zum Abdichten der Einschraubgewinde empfehlen wir unseren Dichtstift «Plasto-Joint» AC 833.

Pour assurer l'étanchéité des filetages mâles, nous recommandons notre bâton «Plasto-Joint» AC 833.

For sealing the male threads we recommend our sealing stick «Plasto-Joint» AC 833.

Schwenkverschraubung

Coude banjo

Single banjo

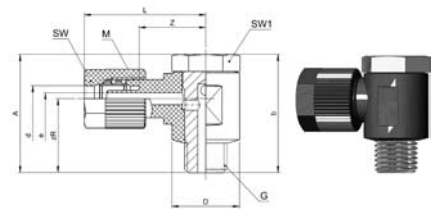
SO 32821

Typ -d-G	Mat.-Nr.	bar	M	SW	SW1	L	A	b	D	zR	z	e	kg/100
G= Rohrgewinde (zylindrisch)	G= Filetage-gaz BSP (cylindrique)	G=BSP thread (straight)											
SO 32821-6-1/8	168.2841.100	10	10 x 1	12	14	27.5	21.0	26.0	16.0	10.5	16.5	2.8	1.950
SO 32821-6-1/4	168.2841.110	10	10 x 1	12	19	27.5	26.0	35.0	20.0	12.5	16.5	2.8	4.080
SO 32821-8-1/8	168.2841.160	10	12 x 1	14	19	29.0	21.0	26.0	16.0	10.5	17.0	4.8	2.040
SO 32821-8-1/4	168.2841.170	10	12 x 1	14	19	29.0	26.0	35.0	20.0	12.5	17.0	4.8	4.160
SO 32821-10-1/4	168.2841.270	10	14 x 1	17	19	32.5	26.0	35.0	20.0	12.5	18.5	6.6	4.360
▼ SO 32821-10/7-1/4	168.2841.320	10	14 x 1	17	19	32.5	26.0	35.0	20.0	12.5	18.5	5.0	4.450
SO 32821-6-M10X1	168.2843.180	10	10 x 1	12	14	27.5	21.0	26.0	16.0	10.5	16.5	2.8	1.960
SO 32821-6-M12X1,5	168.2843.195	10	10 x 1	12	19	27.5	26.0	35.0	20.0	12.5	16.5	2.8	4.050
SO 32821-6-M14X1,5	168.2843.198	10	10 x 1	12	19	27.5	26.0	35.0	20.0	12.5	16.5	2.8	4.050
SO 32821-8-M10X1	168.2843.230	10	12 x 1	14	14	29.0	21.0	26.0	16.0	10.5	17.0	4.8	2.040
SO 32821-8-M12X1,5	168.2843.240	10	12 x 1	14	19	29.0	26.0	35.0	20.0	12.5	17.0	4.8	4.130
SO 32821-8-M14X1,5	168.2843.245	10	12 x 1	14	19	29.0	26.0	35.0	20.0	12.5	17.0	4.8	4.160
SO 32821-10-M12X1,5	168.2843.275	10	14 x 1	17	19	32.5	26.0	35.0	20.0	12.5	18.5	6.6	4.320
SO 32821-10-M14X1,5	168.2843.280	10	14 x 1	17	19	32.5	26.0	35.0	20.0	12.5	18.5	6.6	4.340
▼ SO 32821-10/7-M12X1,5	168.2843.300	10	14 x 1	17	19	32.5	26.0	35.0	20.0	12.5	18.5	5.0	4.420
▼ SO 32821-10/7-M14X1,5	168.2843.305	10	14 x 1	17	19	32.5	26.0	35.0	20.0	12.5	18.5	5.0	4.430

d=Rohrassen-ø

L=Mass in montiertem Zustand

e=kleinste Bohrung

▼=für Rohre mit Wandung 1,5 mm

d=ø extérieur du tube

L=après montage

e=ø min. de passage

▼=pour tubes avec paroi de 1,5 mm d'épaisseur

d=tube outside diameter

L=installed length

e=minimum bore

▼=for tubes with wall thickness of 1,5 mm

2-fach Winkelschwenkverschraubung

Coude banjo multiple

Double banjo

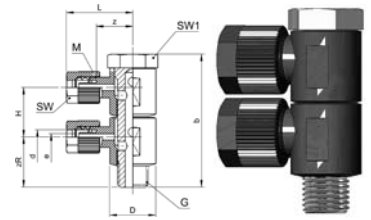

SO 32921

Type -d -G	Mat.-Nr.	bar	M	SW	SW1	L	b	D	H	zR	z	e	kg/100
G= Rohrgewinde (zylindrisch)	G= Filetage-gaz BSP (cylindrique)	G=BSP thread (straight)											
SO 32921-2X6-1/8	168.2941.100	10	10 x 1	12	14	27.5	42.0	16.0	16.0	10.5	16.5	2.8	3.080
SO 32921-2X6-1/4	168.2941.110	10	10 x 1	12	19	27.5	56.0	20.0	21.0	12.5	16.5	2.8	6.140
SO 32921-2X8-1/8	168.2941.160	10	12 x 1	14	14	29.0	42.0	16.0	16.0	10.5	17.0	4.8	3.260
SO 32921-2X8-1/4	168.2941.170	10	12 x 1	14	19	29.0	56.0	20.0	21.0	12.5	17.0	4.8	6.300
SO 32921-2X10-1/4	168.2941.270	10	14 x 1	17	19	32.5	56.0	20.0	21.0	12.5	18.5	6.6	6.700
▼ SO 32921-2X10/7-1/4	168.2941.320	10	14 x 1	17	19	32.5	56.0	20.0	21.0	12.5	18.5	5.0	6.810

Schwenkverschraubung

mit Drossel-Ventil

Coude banjo

à passage réglable

Single banjo

with throttle valve

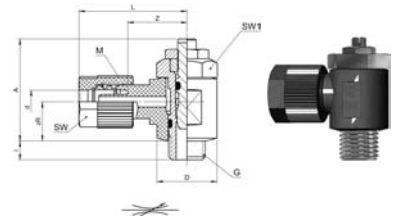

SO 37621

Type -d -G	Mat.-Nr.	bar	M	SW	SW1	L	A	D	i	zR	z	kv	kg/10
G= Rohrgewinde (zylindrisch)	G= Filetage-gaz BSP (cylindrique)	G=BSP thread (straight)											
SO 37621-6-1/8	168.7600.100	10	10 x 1	12	14	27.5	26.0	16.0	6.0	10.5	16.5	3.0	0.210
SO 37621-6-1/4	168.7600.110	10	10 x 1	12	19	27.5	30.5	20.0	9.0	12.5	16.5	6.0	0.440
SO 37621-8-1/8	168.7600.160	10	12 x 1	14	14	29.0	26.0	16.0	6.0	10.5	17.0	3.0	0.280
SO 37621-8-1/4	168.7600.170	10	12 x 1	14	19	29.0	30.5	20.0	9.0	12.5	17.0	6.0	0.450
SO 37621-10-1/4	168.7600.270	10	14 x 1	17	19	32.5	30.5	20.0	9.0	12.5	18.5	6.0	0.460

Dieses Drossel-Ventil dient zur Regulierung von Luftströmen in beiden Richtungen. Die Kombination von Verschraubung und Drossel-Ventil erlaubt den Anbau direkt an den Zylinder. Die Spindelfixierung mittels Kontermutter garantiert, dass sich die Spindel auch bei Vibration nicht verstell.

Technische Hinweise:

Körper und Anschlussmutter aus Polyamid 6.6, O-Ringe aus NBR. Hohlschrauben und Ventileinsätze aus Messing.

Schwenkverschraubungen siehe SO 32821, SO 32921, SO 33821, SO 33921 und SO 42821, SO 42921, SO 43821 und SO 43921.

Cet élément d'étranglement sert au réglage d'écoulements d'air dans les deux sens. La combinaison raccord-passage réglable est spécialement destinée au montage sur le cylindre. La fixation de la broche à l'aide d'un contre-écrou garantit la stabilité du réglage même en cas de vibrations.

Données techniques:

Corps et écrous de raccords en polyamide 6.6, joints toriques en NBR. Vis creuse et ponteau en laiton.

Coudes banjo voir SO 32821, SO 32921, SO 33821, SO 33921 et SO 42821, SO 42921, SO 43821 et SO 43921.

This throttle valves serve to regulate air flow in both directions. The combination of union and throttle valve permits direct fitting to the cylinder. The spindle fixation via counter-nut assures that the spindle can not shift, even due to vibration.

Technical notes:

Bodies and union nuts of polyamide 6.6, O-Rings of NBR. Hollow screws and valve parts of brass.

Single banjo please see SO 32821, SO 32921, SO 33821, SO 33921 and SO 42821, SO 42921, SO 43821 and SO 43921.

d=Rohrassen-ø
kv=Kenngröße für das Durchflussverhalten (litr./min)
L=Mass in montiertem Zustand
e=kleinste Bohrung
▼=für Rohre mit Wandung 1,5 mm

d=ø extérieur du tube
kv=facteur d'écoulement (litr./min)
L=après montage
e=ø min. de passage
▼=pour tubes avec paroi de 1,5 mm d'épaisseur

d=tube outside diameter
kv=flow factor (litr./min)
L=installed length
e=minimum bore
▼=for tubes with wall thickness of 1,5 mm

Schwenkverschraubung

mit Drossel-Rückschlag-Ventil

Coude banjo

à passage réglable et soupape de retenue

Single banjo

with throttle valve and non-return

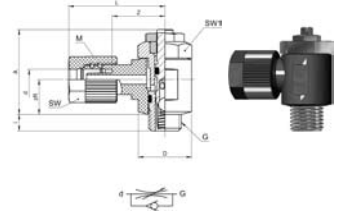

SO 37721

Type -d -G	Mat.-Nr.	bar	M	SW	SW1	L	A	D	i	zR	z	kv	kg/10
G= Rohrgewinde (zylindrisch)													
G= Filetage-gaz BSP (cylindrique)													
G=BSP thread (straight)													
SO 37721-6-1/8	168.7700.100	10	10 x 1	12	17	27.5	26.0	16.0	6.0	10.5	16.5	3.0	0.210
SO 37721-6-1/4	168.7700.110	10	10 x 1	12	19	27.5	30.5	20.0	9.0	12.5	16.5	6.0	0.430
SO 37721-8-1/8	168.7700.160	10	12 x 1	14	17	29.0	26.0	16.0	6.0	10.5	17.0	3.0	0.240
SO 37721-8-1/4	168.7700.170	10	12 x 1	14	19	29.0	30.5	20.0	9.0	12.5	17.0	6.0	0.450
SO 37721-10-1/4	168.7700.270	10	14 x 1	17	19	32.5	30.5	20.0	9.0	12.5	18.5	6.0	0.460

Einschraubtülle

Douille cannelée à visser

Male adaptor hose nozzle

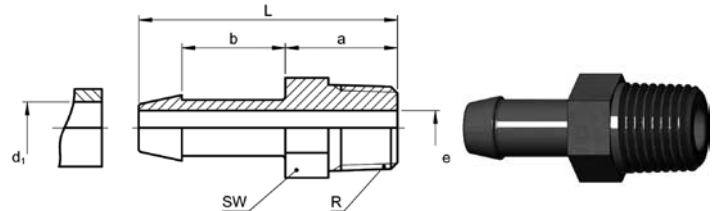

SO 30511

Type -d1 -R	Mat.-Nr.	bar	SW	L	a	b	e	kg/100
R= Rohrgewinde (kegelig)								
R= Filetage-gaz BSP (conique)								
R=BSP thread (tapered)								
SO 30511-6-1/8	166.0511.100	10	10	30.0	13.0	12.0	4.0	0.120
SO 30511-6-1/4	166.0511.110	10	14	35.5	18.5	12.0	4.0	0.280
SO 30511-8-1/4	166.0511.170	10	14	35.5	18.5	12.0	6.0	0.290
SO 30511-10-3/8	166.0511.280	10	17	38.0	19.0	14.0	7.0	0.480
SO 30511-12-3/8	166.0511.390	10	17	38.0	19.0	14.0	10.0	0.410
SO 30511-12-1/2	166.0511.400	10	22	43.0	24.0	14.0	10.0	0.800

Für die Schlauchsicherung verwenden Sie bitte unsere Schlauchklemme SO 40512 (Stahl promatverzinkt).

Afin d'assurer la bonne tenue des tuyaux, utiliser nos colliers de serrage SO 40512 (Acier zingué passivé).

Please use our hose clip SO 40512 (zinc promatised) for securing the hose.

d1 = Schlauchinnen-Ø
e = kleinste Bohrung

d1 = Ø intérieur du tuyau
e = Ø min. de passage

d1 = hose inside diameter
e = minimum bore